



PV/Storage Inverter Functions

EPRI Project and NIST Priority Action Plan: PAP 7

Frances Cleveland
Xanthus Consulting International

Current TC57 Reference Architecture – Scope and Layers

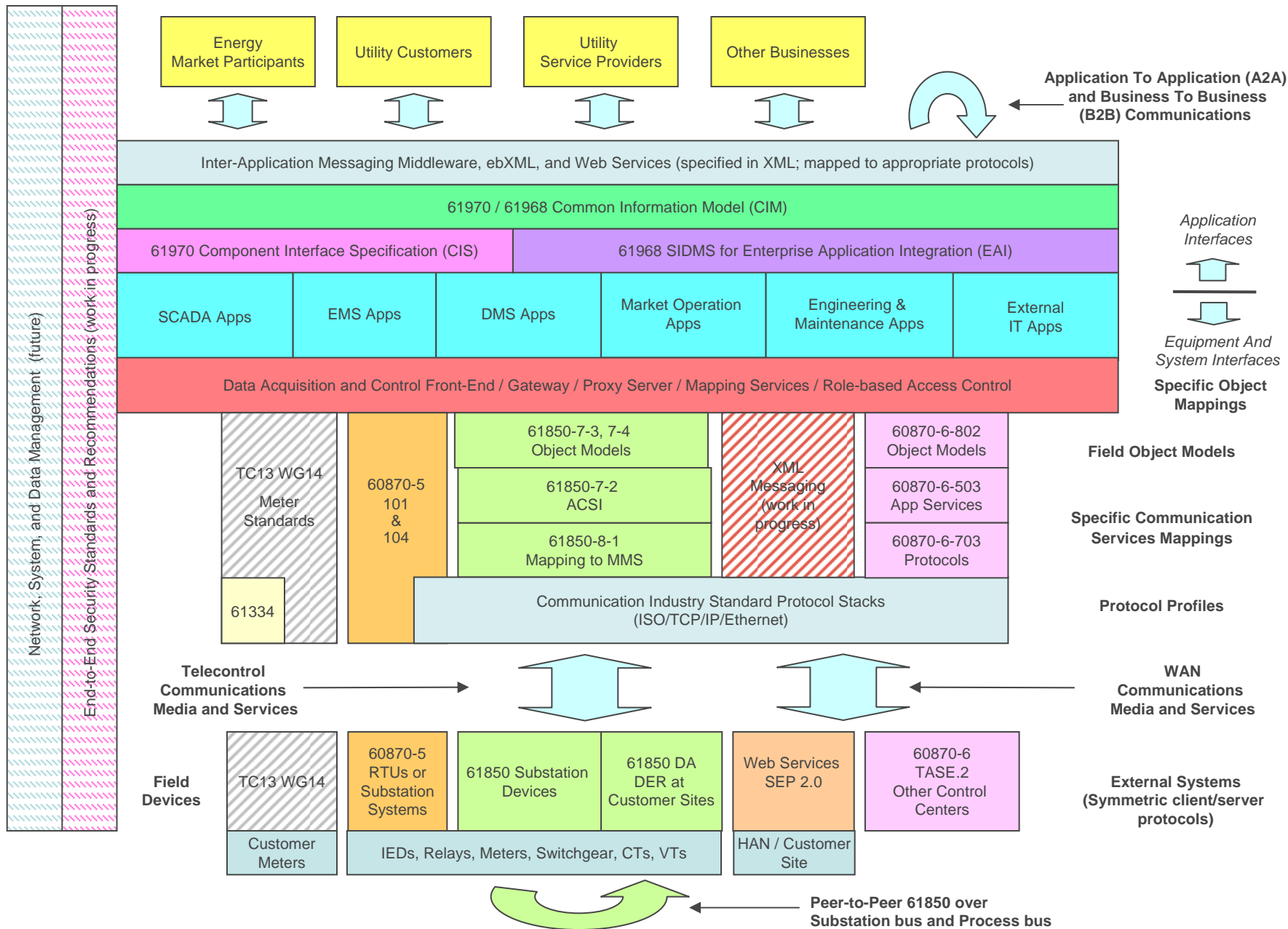

1) Solid patterns represent IEC TC protocols within the architecture.
 2) Non-solid patterns represent areas that are future work, or work in progress, or related work provided by another IEC TC.

Current TC57 Reference Architecture – Scope and Layers

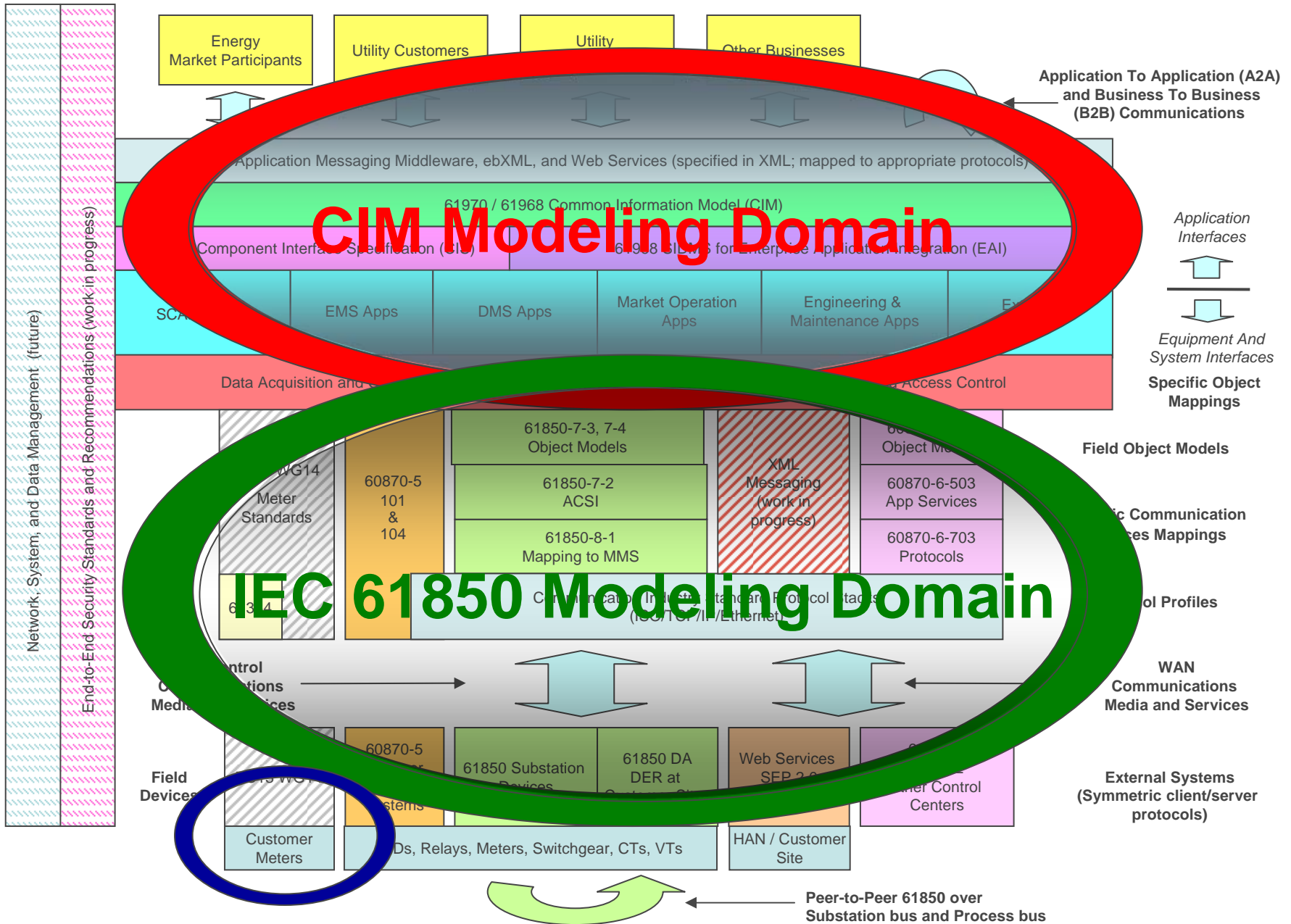

1) Solid patterns represent areas that are complete or in progress, while non-solid patterns represent areas that are future work, or work in progress, or related work provided by another IEC TC.
 2) Non-solid patterns represent areas that are future work, or work in progress, or related work provided by another IEC TC.

DER (Generation and Storage) Functions and Interactions

- DERs will provide:
 - Energy (real power) from generators and from storage units
 - Reactive power support (volt/var support) to both distribution and transmission efficiency and stability
 - Combined generation and storage can provide rapid response to mitigate intermittent renewable resources like wind and solar
 - Low voltage ride-through, emergency reserves, harmonic-damping
 - Rapid response to frequency deviations
- DER will be managed:
 - By customers for their own exclusive use
 - Through direct control by utilities or aggregators
 - Through market-driven bids, with direct control by utilities
 - Through market-driven, tariff-based demand response

Different DER Interactions: Direct Control, Interactive Requests, Broadcast/Multicast

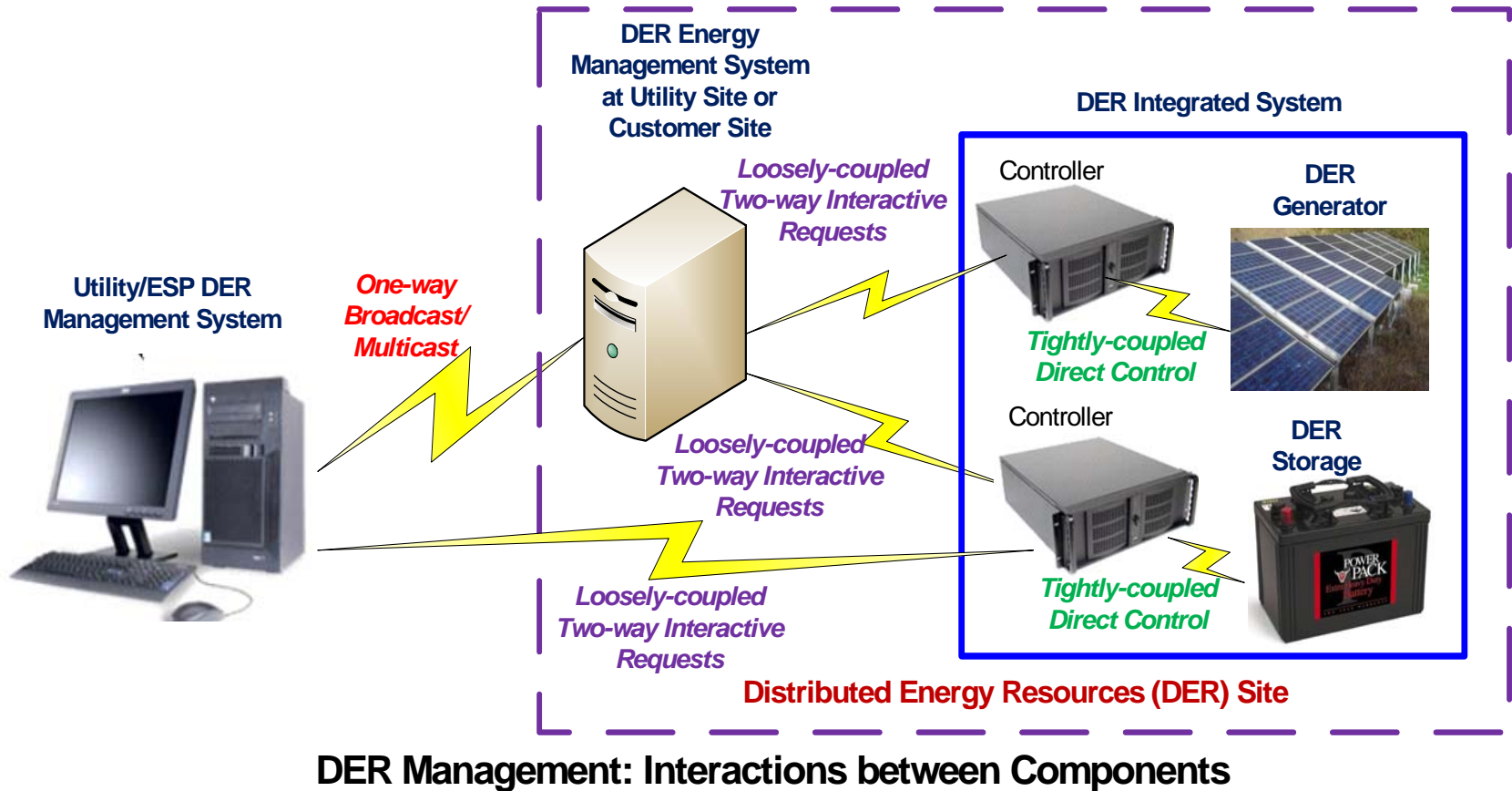

DER Key Use Cases Must Cope with Many Different Configurations

- Direct, tightly-coupled control
 - Between inverter controller and ES-DER device
 - Between Customer EMS and multiple ES-DER devices in a building, subdivision, or campus
- Interactive two-way monitoring and control
 - Between ISO/RTO and ES-DER system whose bid has been accepted
 - Between Customer EMS and multiple ES-DER systems with their own (sophisticated) controllers
- Broadcast/multicast one-way “pricing” or “request” signals
 - Between utility and Customer EMS
 - Between aggregator and ES-DER systems

PV/Storage Inverter-based System Phase 1 Functions and Interactions

Phase 1 Functions

- Connect/Disconnect from grid
- Limit maximum generation
- Set power factor
- Var settings, based on voltage
- Var settings, based on watts
- Storage charge / discharge rate
(fast PEV chargers??)
- “Pricing” signal
- Event / history logging
- State / status reporting
- Time synchronization

Interaction

- Direct command
- Immediate request
- Change settings
- Schedule of settings based on time
- Schedule of settings based on temperature

Phase 2 Functions

- Low voltage ride-through!!
- Counteracting frequency deviation
- Other

One PV/Storage Inverter Mode

Mode PV1 – Normal Energy Conservation Mode

Example Settings

Voltage Array		VAR Array (%)	
V1	115	Q1	100
V2	118	Q2	0
V3	122	Q3	0
V4	126	Q4	-100

VAR Ramp Rate Limit – fastest allowed change in VAR output in response to either power or voltage changes	50 [%/second]
Randomization Interval – time window over which mode or setting changes are to be made effective	60 seconds

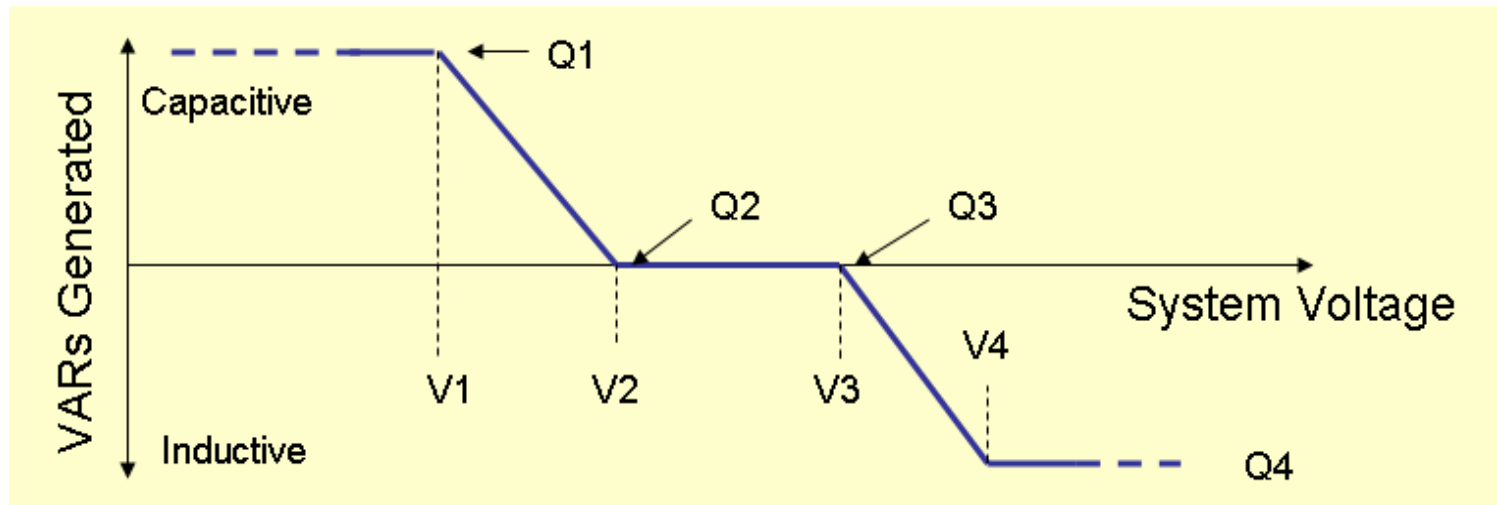

IEC 61850-7-420 for DER

- IEC 61850 – Interface Standard of Object Models for Utility Industry
 - Very modular
 - Establishes “well-known” standardized names, data formats, and services
 - Initially focused on substation automation, but now being expanded
- IEC 61850-7-420 for DER
 - Addresses only the “Nouns”
 - IEC 61850 object modeling constructs of LNs, etc:
- Covers:
 - General DER management
 - Photovoltaic systems
 - Fuel cells
 - Diesel generation
 - Combined heat and power
 - Wind power is handled separately (IEC 61400-25)
- Currently status is Final Draft International Standard (FDIS)
 - Due to become International Standard (IS) by mid-2008

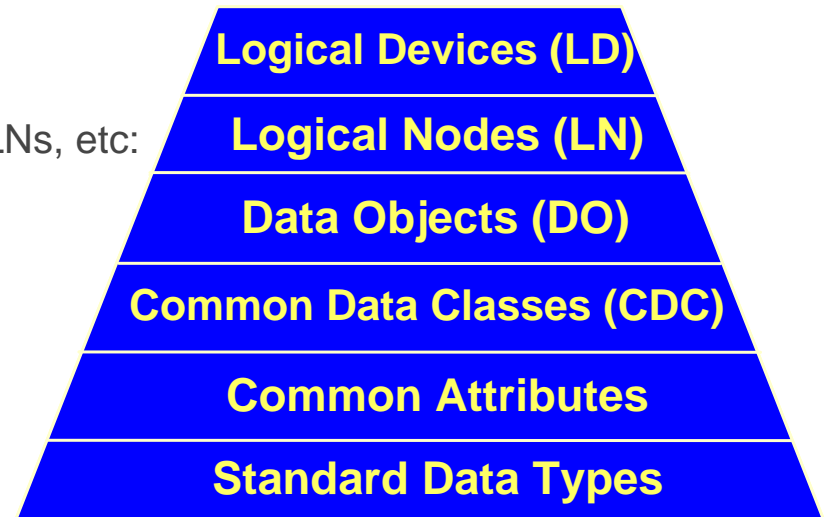

Possible Inverter Logical Device

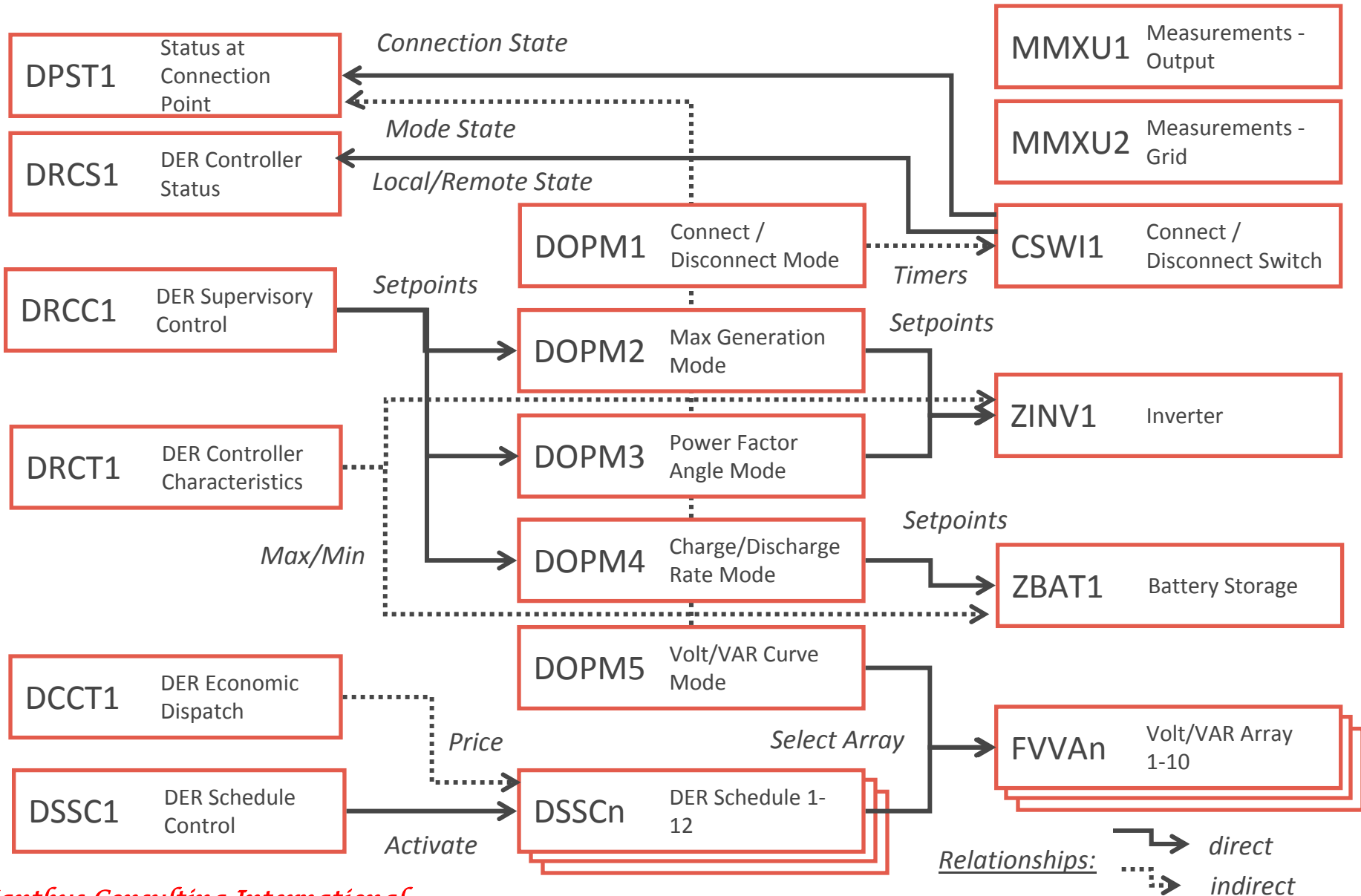

Mapping to DNP3

3	LN	Inst	Data Object	CDC	IEC 61850 Description	T	M/O	New?	PV?	Fn	DNP3?	PV Description
4	CSWI	1		LN					Y	PC1	Y	Connect/Disconnect Switch
7	CSWI	1	Pos	DPC	Switch, general		M		Y	PC1	Y	Connect status - status of the device's connect/
13	DOPM	1		LN					Y	PC1	Y	Operating Mode - Connect/Disconnect
28	DOPM	1	WinTms	ING	Time window within which to randomly		O	Y	Y	PC1	Y	Time window for Connect/Disconnect
29	DOPM	1	RevtTms	ING	Timeout period - revert to defaults		O	Y	Y	PC1	Y	Timeout period for Connect/Disconnect
31	DOPM	2		LN					Y	PC2	Y	Operating mode - Maximum Generation
43	DOPM	2	OpModWLim	SPC	Mode of operation - limited Watts, as p		O	Y	Y	PC2	Y	Mode of operation - limited Watts
46	DOPM	2	WinTms	ING	Time window within which to randomly		O	Y	Y	PC2	Y	Time window for limited Watts mode
47	DOPM	2	RevtTms	ING	Timeout period - revert to defaults		O	Y	Y	PC2	Y	Timeout period for limited Watts mode
48	DOPM	2	RmpTms	ING	Ramp time		O	Y	Y	PC2	Y	Ramp time for limited Watts mode
49	DOPM	3		LN					Y	PC3	Y	Operating mode - Power Factor Angle
55	DOPM	3	OpModPFAng	SPC	Mode of operation - power factor angle		O	Y	Y	PC3	Y	Mode of operation - maintaining fixed power fa
64	DOPM	3	WinTms	ING	Time window within which to randomly		O	Y	Y	PC3	Y	Time window for fixed power factor angle mode
65	DOPM	3	RevtTms	ING	Timeout period - revert to defaults		O	Y	Y	PC3	Y	Timeout period for fixed power factor angle mo
66	DOPM	3	RmpTms	ING	Ramp time		O	Y	Y	PC3	Y	Ramp time for fixed power factor angle mode
67	DOPM	4a		LN					Y	PC4a	Y	Operating Mode - Charge or Discharge Rate
80	DOPM	4a	OpModWRte	SPC	Mode of operation - charge or discharge		O	Y	Y	PC4a	Y	Mode of operation - charge or discharge rate
82	DOPM	4a	WinTms	ING	Time window within which to randomly		O	Y	Y	PC4a	Y	Time window for charge or discharge rate mode
83	DOPM	4a	RevtTms	ING	Timeout period - revert to defaults		O	Y	Y	PC4a	Y	Timeout period for charge or discharge rate mo
84	DOPM	4a	RmpTms	ING	Ramp time		O	Y	Y	PC4a	Y	Ramp time for charge or discharge rate mode

UML Diagrams of IEC 61850 – CDCs, Data Sets, and Logical Nodes

– Being Used for Mapping to SEP 2.0

Common Data Classes

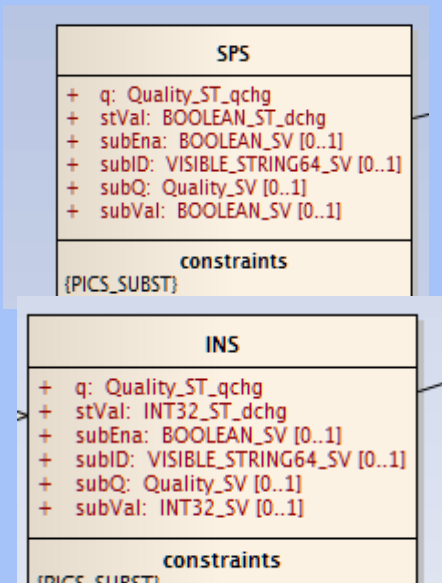

Datasets are list of signal references, used for logging and eventing on data and/or quality change. They allow the application to "read" that list of references once, and then receive value updates as ordered lists of values. In the meta-model, datasets contain thus only information on contained references, as well as the naming-related services. Communication services are defined in CoreAcSi API.

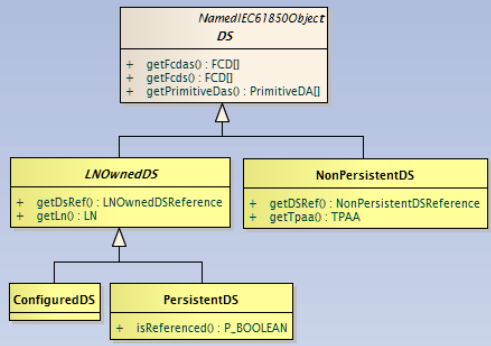

Logical Nodes

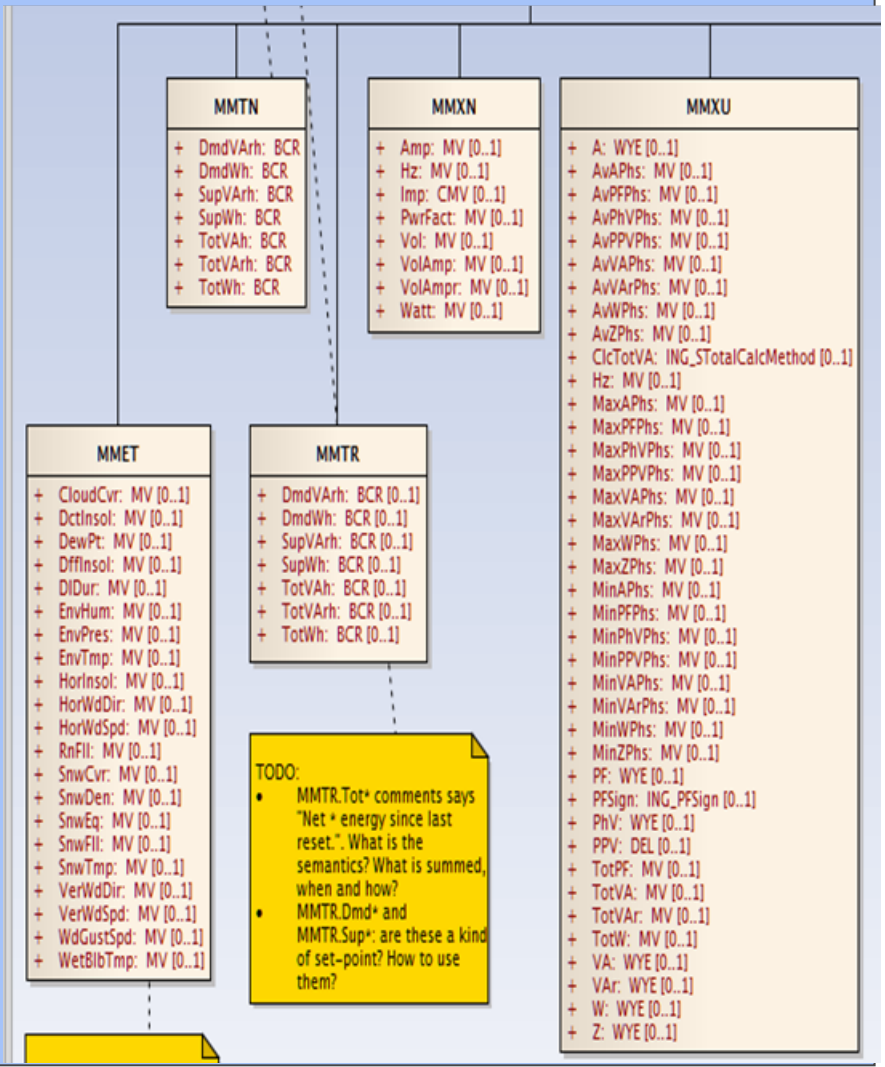

TODO:

- MMTR.Tot+ comments says "Net + energy since last reset.". What is the semantics? What is summed, when and how?
- MMTR.Dmd+ and MMTR.Sup+ are these a kind of set-point? How to use them?

IEC 61850-7-420 Abstract Information Models

(*Italic indicates new DO*)

DOPM

DOPM class (existing in IEC 61850-7-420)				
Data object name	Common data class	Explanation	T	M/O/C
<i>Settings</i>				
<u>WinTms</u>	ING	Time window (in seconds) within which to randomly execute a command. If the time window is zero, the command will be executed immediately		O
<u>RevtTms</u>	ING	Timeout period (in seconds), after which the device will revert to its default status, such as closing the switch to reconnect to the grid		O
<u>RmpTms</u>	ING	Ramp time, in seconds, for moving from current operational mode settings to new operational mode settings		O
<i>Controls</i>				
<u>OpModWLim</u>	SPC	Mode of operation – limited watts, as percentage of nominal watts – in SPC: <ul style="list-style-type: none">• <u>ctlVal</u> = off (FALSE) on (TRUE)		P
<u>OpModPFAng</u>	SPC	Mode of operation – maintaining fixed power factor – in SPC: <ul style="list-style-type: none">• <u>ctlVal</u> = off (FALSE) on (TRUE)		P

DRCC

DRCC class (existing in IEC 61850-7-420)				
Data object name	Common data class	Explanation	T	M/O/C
<i>Settings</i>				
<u>MaxLimWPct</u>	ING	Percent of nominal watts as maximum allowed watts output – in ING: <ul style="list-style-type: none">• <u>setVal</u> = percentage value between <u>minVal</u> and <u>maxVal</u>• <u>minVal</u> = 0% (or larger number)• <u>maxVal</u> = 100%		0

New LN: FVVA – Scheduling with Pairs of Volt/Var Settings

<i>FVVA class (new, to be added to IEC 61850-7-420)</i>				
Data object name	Common data class	Explanation	T	M/O/C
<i>Settings</i>				
<u><i>VolVarId</i></u>	ING	Identity of this paired volt/var array		M
<u><i>VolVarSet</i></u>	CSG	Paired array of voltage values and var percent of <u>Qmax</u> : For <u>crvPts</u> : <u>xVal</u> = voltage values <u>yVal</u> = var percent of <u>Qmax</u>		M
<u><i>WinTms</i></u>	ING	Time window (in seconds) within which to randomly execute the command using this array. If the time window is zero, the command will be executed immediately		O
<u><i>RmpTms</i></u>	ING	Ramp time, in seconds, for moving to the var settings in the volt/var array		O

DSCH Schedule by Temperature Range

DSCH class																										
Data Object Name	Common Data Class	Explanation	T	M/O/C																						
<i>Settings</i>																										
<u>SchdId</u>	ING	Non-zero identity of the schedule		M																						
<u>SchdTmp</u>	CSG	Array of energy targets for each temperature range: For <u>crvPts</u> : <u>xVal</u> = energy target values (<u>SchdVal</u>) <u>yVal</u> = temperature range (<u>yVal</u> (n) > <u>yVal</u> (n-1) for <u>yVal</u> (0..n))		M																						
<u>SchdVal</u>	ING	Meaning of the <u>val</u> parameter in the SCA or SCR: <table border="1" data-bbox="730 792 1503 1288"> <thead> <tr> <th>Value</th> <th>Explanation</th> </tr> </thead> <tbody> <tr> <td>0</td> <td>Not applicable / Unknown</td> </tr> <tr> <td>1</td> <td>Active power</td> </tr> <tr> <td>2</td> <td>Reactive power</td> </tr> <tr> <td>3</td> <td>Power factor</td> </tr> <tr> <td>4</td> <td>Voltage</td> </tr> <tr> <td>5</td> <td>Price for active power</td> </tr> <tr> <td>6</td> <td>Price for reactive power</td> </tr> <tr> <td>7</td> <td>Heat</td> </tr> <tr> <td>8</td> <td><i>Volt/Var array identifier</i></td> </tr> <tr> <td>99</td> <td>Other</td> </tr> </tbody> </table>	Value	Explanation	0	Not applicable / Unknown	1	Active power	2	Reactive power	3	Power factor	4	Voltage	5	Price for active power	6	Price for reactive power	7	Heat	8	<i>Volt/Var array identifier</i>	99	Other		O
Value	Explanation																									
0	Not applicable / Unknown																									
1	Active power																									
2	Reactive power																									
3	Power factor																									
4	Voltage																									
5	Price for active power																									
6	Price for reactive power																									
7	Heat																									
8	<i>Volt/Var array identifier</i>																									
99	Other																									

SCR – Relative time schedule settings

SCR Class						
Data Object Name	Attribute type	FC	TrgOp	Value/value range	M/O/C	
DataName	Inherited from data class (see IEC 61850-7-2)					
DataAttribute						
<i>setting</i>						
numPts	INT16U	SP		Length of array >= 1	AC_NSG_M	
val	ARRAY 1..numPts OF FLOAT32	SP	dchg	1 to numPts values	AC_NSG_M	
rmpTyp	ARRAY 1..numPts OF ENUMERATED	SP	dchg	1 to numPts values: 1=Fixed, 2=Ramp, 3=Average	AC_NSG_C	
tmsOffset	ARRAY 1..numPts OF UINT24	SP	dchg	1 to numPts of time offsets in seconds	AC_NSG_M	
<i>configuration, description and extension</i>						
cur	VISIBLE STRING3	CF		Currency as 3-character string as per ISO 4217	O	
occPer	Enumerated	CF		Repeat period (Hour, Day, Week, Month, Year)	O	
valUnits	Unit	CF		Units of val	O	
valEq	ENUMERATED	CF		Equation for val: 1 = SI units, 2 = Currency as per ISO 4217 per SI unit, 3 = SI unit per currency	O	
valD	VISIBLE STRING255	DC		Description of val	O	
valDU	UNICODE STRING255	DC		Description of val in Unicode	O	
d	VISIBLE STRING255	DC		Description of instance of data	O	

Activation of Schedules

DSCC class				
Status information				
<u>ActWSchdSt</u>	INS	Indication of which energy schedule is active – schedule 0 indicates no schedule		M
<u>ActAncSchdSt</u>	INS	Indication of which ancillary services schedule is active – schedule 0 indicates no schedule		M
Controls				
<u>ActWSchd</u>	ENC	Activate specific energy schedule, using <u>TimeActivatedOperate</u> (see IEC 61850-7-2) to establish start time for schedules using relative time and if start time is in the future. <u>ctrVal</u> : 0 = deactivate, 1 = activate		M
<u>ActAncSchd</u>	SPC	Activate specific ancillary services schedule, using <u>TimeActivatedOperate</u> to establish start time for schedules using relative time and if start time is in the future. <u>ctrVal</u> : 0 = deactivate, 1 = activate		M
<u>ActTmpSchd</u>	ENC	Activate temperature-based schedule: <u>ctrVal</u> : 0 = deactivate, 1 = activate, time-activated		O
<u>ActPriceSchd</u>	ENC	Activate pricing signal-based schedule: <u>ctrVal</u> : 0 = deactivate, 1 = activate		O



Discussions??? !!!